

Connector Block & Plate

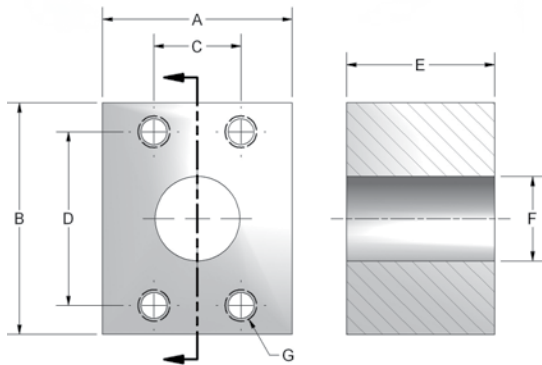

Used to connect two o-ring flanges

CODE 61 CONNECTOR BLOCK								
PART NO.	PAD SIZE	A	B	C	D	E	F	G UNC-2B
ACB 8-8	.50	2.00	2.12	.688	1.500	1.75	.502	5/16-18
ACB 12-12	.75	2.00	2.62	.875	1.875	1.75	.752	3/8-16
ACB 16-16	1.00	2.25	2.75	1.031	2.062	1.75	1.002	3/8-16
ACB 20-20	1.25	3.00	3.19	1.188	2.312	2.125	1.252	7/16-14
ACB 24-24	1.50	3.50	3.75	1.406	2.750	2.125	1.502	1/2-13
ACB 32-32	2.00	3.88	4.00	1.688	3.062	2.125	1.942	1/2-13
ACB 40-40	2.50	4.38	4.50	2.000	3.500	2.375	2.442	1/2-13



CODE 62 CONNECTOR BLOCK								
PART NO.	PAD SIZE	A	B	C	D	E	F	G UNC-2B
ACBX 8-8	.50	2.00	2.22	.718	1.594	1.75	.502	5/16-18
ACBX 12-12	.75	2.50	2.81	.937	2.000	2.00	.752	3/8-16
ACBX 16-16	1.00	2.75	3.19	1.093	2.250	2.00	1.002	7/16-14
ACBX 20-20	1.25	3.00	3.75	1.250	2.625	2.00	1.252	1/2-13
ACBX 24-24	1.50	3.88	4.50	1.437	3.125	2.50	1.502	5/8-11
ACBX 32-32	2.00	4.50	5.25	1.750	3.812	2.95	1.942	3/4-10

CODE 61 CONNECTOR PLATE							
PART NO.	PAD SIZE	A	B	C	D	E	F
8 CP	.50	1.81	2.12	.688	1.500	.50	.344
12 CP	.75	2.06	2.56	.875	1.875	.75	.406
16 CP	1.00	2.31	2.75	1.031	2.062	1.00	.406
20 CP	1.25	2.88	3.12	1.188	2.312	1.25	.469
24 CP	1.50	3.25	3.69	1.406	2.750	1.50	.531
32 CP	2.00	3.81	4.00	1.688	3.062	2.00	.531
40 CP	2.50	4.12	4.44	2.000	3.500	2.50	.531
48 CP	3.00	5.16	5.31	2.438	4.188	3.00	.656



CODE 62 CONNECTOR PLATE							
PART NO.	PAD SIZE	A	B	C	D	E	F
12 CPX	.75	2.38	2.81	.937	2.000	.750	.406
16 CPX	1.00	2.75	3.19	1.093	2.250	1.000	.469
20 CPX	1.25	3.06	3.75	1.250	2.625	1.250	.531
24 CPX	1.50	3.75	4.44	1.437	3.125	1.500	.656
32 CPX	2.00	4.50	5.25	1.750	3.812	2.000	.781

